

Standard hydraulic power packs type SSH

vertical motor, submersed pump - reservoir capacity 10, 25 and 50 liters

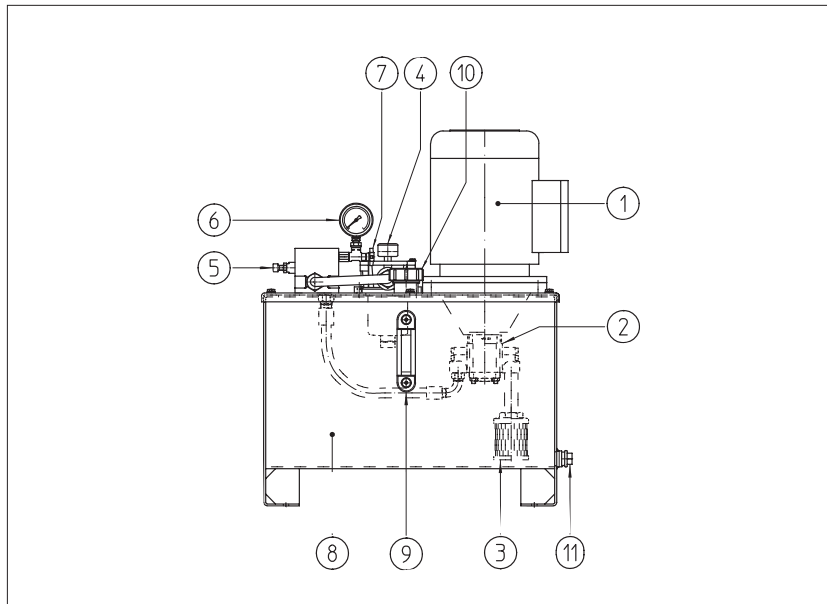

SSH hydraulic power packs are compact design standard units made according to machinery directive 2006/42/CE with vertical motor pump unit.

Electric motors and pumps are available in different variants, modular subplates type BA-244/*, to realize customized hydraulic circuits with modular and directional valves (ISO 4401 size 06), can be assembled and mounted on the cover.

Basic version is composed by:

- ① electric motor coupled with hydraulic pump ②;
- ③ suction submersed filter;
- ④ return filter with visual clogging indicator;
- ⑤ pressure relief valve;
- ⑥ glycerine filled pressure gauge Ø 60 with shut-off valve ⑦;
- ⑧ reservoir with visual oil level ⑨, filling plug with air filter ⑩ and emptying ⑪.

1 MODEL CODE

SSH	-	25	/	G	142	-	1,1	S	/	R	**
Type of hydraulic								Design number			
Reservoir capacity: 10 = 10 liters 25 = 25 liters 50 = 50 liters								Options: /R = check valve on P line /V = reservoir with oil collecting bottom lip.			
Type of pump G = gear pump type PFG (see tab. SA055)								Eventual suffix S = without electric motor			
Pump displacement, see section 4 for available combinations: 114 = 1,3 cm ³ /rev 128 = 2,7 cm ³ /rev 142 = 4,1 cm ³ /rev 160 = 6,1 cm ³ /rev 174 = 7,4 cm ³ /rev 187 = 9,1 cm ³ /rev 199 = 10,8 cm ³ /rev Other displacements are available on request								Electric motor power, see section 4 0,4 = 0,37 kW 0,7 = 0,75 kW 1,1 = 1,1 kW 1,5 = 1,5 kW 2,2 = 2,2 kW 3 = 3 kW 4 = 4 kW Supply voltages, see section 4			

2 HYDRAULIC SCHEMES

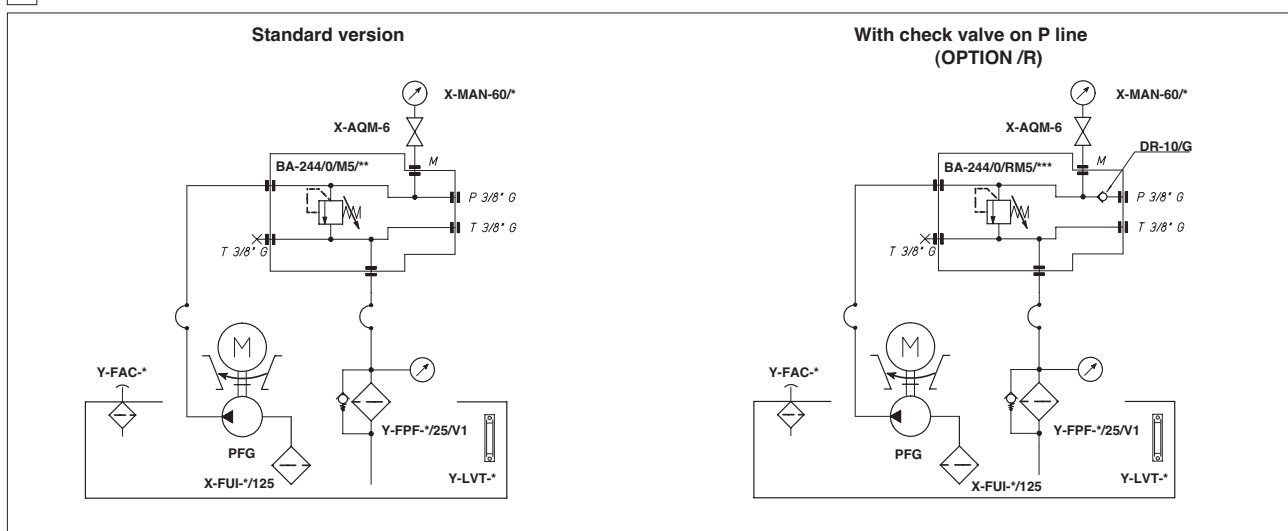

3 MAIN CHARACTERISTICS

Installation position	Horizontal: electric motor with vertical axis
Ports	Ports P and T at G 3/8"
Customized circuits	<p>Customized circuits can be easily realized by means of modular plates type BA-244/*, (see tab. SK290), modular valves size ISO 4401 size 06, solenoid valves and directional valves type DH*.</p> <p>In particular:</p> <ul style="list-style-type: none"> • assemble on the subplate BA-244/0/** installed on the power-pack cover, the required number of intermediate multistation subplates BA-244/* (max 10 stations); • modular control valves type HMP, HM, HS, HG, HC, HQ, HR, solenoid valves and directional valves type DH* can be mounted on these intermediate plates according to the requested hydraulic.
Fluid	Hydraulic oil as per DIN 51524...535; for other fluids contact our technical office
Recommended viscosity	15 ÷ 100 mm ² /s at 40°C (ISO VG 15 ÷ 100).
Fluid contamination class	ISO 19/16, achieved with in line filters at 25 µm and ≥ 75 (recommended)
Fluid temperature	-20°C +60°C (standard and /WG seals) -20°C +80°C (/PE seals)
Ambient temperature	from -20° C to + 70° C

Note: On the SSH-10 -HPU- the return filter is not present.

4 HYDRAULIC CHARACTERISTICS

Model	Pump type	Flow rate at 1450 rpm and 7 bar [l/min]	Maximum pressure [bar] with motor's power:							Capacity of reservoir [liters]
			0,37 kW size UNEL 71 (1)	0,75 kW size UNEL 80 (1)	1,1 kW size UNEL 90 (1)	1,5 kW size UNEL 90 (1)	2,2 kW size UNEL 100 (1)	3 kW grandezza UNEL 100 (1)	4 kW grandezza UNEL 112 (1)	
Motor Mass	-	-	7,5 Kg	9 Kg	13,5 Kg	14 Kg	23 Kg	23 Kg	30 Kg	-
SSH-10/G114	PFG-114	2	80 (3)	-	-	-	-	-	-	10
SSH-10/G128	PFG-128	3,7	45 (2)	-	-	-	-	-	-	25
SSH-25/G114	PFG-114	2	-	160 (3)	-	-	-	-	-	
SSH-25/G128	PFG-128	3,7	-	90 (3)	130 (3)	180 (3)	-	-	-	
SSH-25/G142	PFG-142	5,7	-	60 (2)	90 (3)	120 (3)	-	-	-	
SSH-25/G160	PFG-160	8,5	-	40 (2)	60 (2)	80 (3)	-	-	-	
SSH-25/G174	PFG-174	10,5	-	30 (2)	50 (2)	65 (2)	-	-	-	
SSH-50/G160	PFG-160	8,5	-	-	-	-	120 (3)	170 (3)	-	50
SSH-50/G174	PFG-174	10,5	-	-	-	-	100 (3)	130 (3)	-	
SSH-50/G187	PFG-187	13	-	-	-	-	80 (3)	110 (3)	150 (3)	
SSH-50/G199	PFG-199	15,2	-	-	-	-	70 (2)	90 (3)	120 (3)	

(1) Electric motor is: three phases, 4 poles, closed and ventilated, construction shape B5, V 230/400 - 50/60 Hz (other voltages available on request).

(2) Pressure relief valves type BA-244/0/**M5/100 and manometers type X-MAN-60/100.

(3) Pressure relief valves type BA-244/0/**M5/210 and manometers type X-MAN-60/250

5 MAIN COMPONENTS

Model	UNEL size of electric motor	Coupling	Bell housing	Suction filter	Return filter	Cartridge of return filter	Filling cap
SSH-10/G	71	Y-GA-11	Y-LMC1G1	X-FUI-25/125	-	-	Y-FAC-30
SSH-25/G	80	Y-GA-21	Y-LMC2G1	X-FUI-25/125	Y-FPF-030/25/V1	SP-PF-030/A25	Y-FAC-70
SSH-25/G	90	Y-GA-41					
SSH-50/G	100	Y-GA-61	Y-LMC4G1	X-FUI-40/125	Y-FPF-100/25/V1	SP-PF-100/A25	Y-FAC-70
SSH-50/G	112						

6 DIMENSIONS [mm]

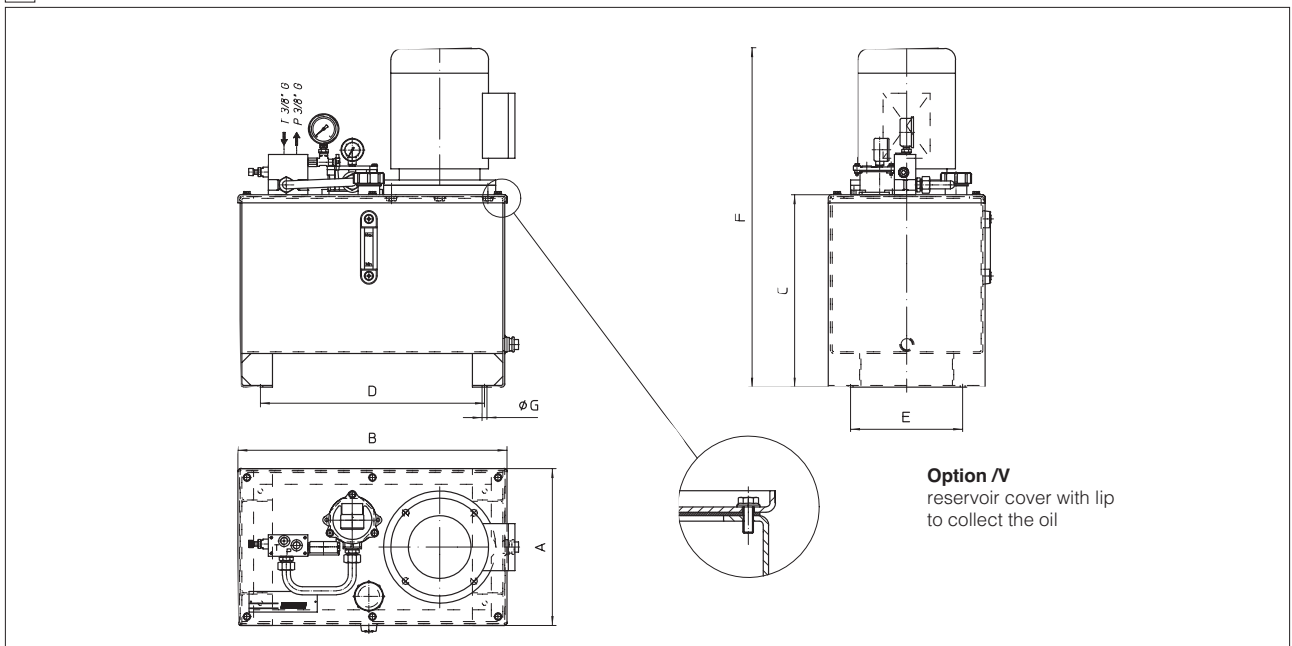

Model	A	B	C		D (max) (1)	E	F	G buttonholes	Mass (2) [kg]
			STD	OPZ. /V					
SSH-10	200	400	245	260	456	300	100	21x11	12
SSH-25	300	500	325	340	575	400	200	21x11	24
SSH-50	350	600	430	445	757	500	250	21x11	43

(1) The dimension refers to the assembly with the standard electric motor in the biggest size (see section 4)

(2) The mass refers to the unit without electric motor and without oil.