

Electronic pressure switches type E-DAP-2

digital, with integral digital display

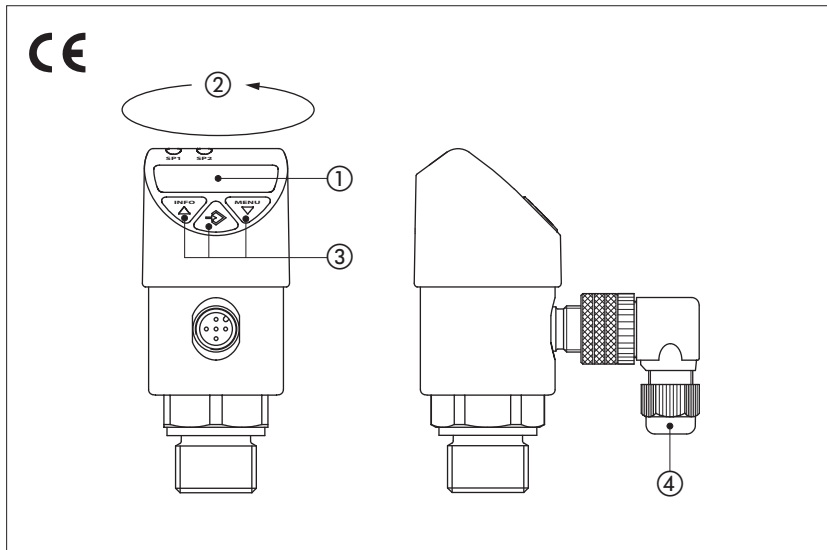

E-DAP-2 is a compact electronic pressure switch with integral digital display, available for 3 different pressure ranges.

The working pressure is real time measured and monitored on a 4 digits display (1) in bar, Mpa, kPa, psi or kg/cm². The display can be mechanically rotated on 1 axis (2) and turned electronically through 180°.

It provides two independent output with electronic contacts which are triggered when the pressure in the hydraulic circuit reaches the switch point or window (see section (4)).

The functional parameters as the pressure switching point, hysteresis range, pressure measuring units and others additional functions can be easily set by the end user through proper programming keys (3).

For detailed instructions about the use of the electronic pressure switch refer to the operating manual supplied with the instrument.

Features:

- Standard 5 pin M12 main connector (4)
- IP65 / IP67 protection degree
- CE mark according to EMC directive

1 MODEL CODE

E-DAP-2	-	250	/	2	*
Electronic pressure switch					Series number
Pressure range: 100 = 100 bar 250 = 250 bar 400 = 400 bar				2 = 2 switching outputs	

2 MAIN CHARACTERISTICS

Model	E-DAP-2-100	E-DAP-2-250	E-DAP-2-400
Pressure measuring range [bar] (1)	0,5 ÷ 100	1,25 ÷ 250	2 ÷ 400
Overload pressure	2 x FS		
Response time	≤ 10 ms		
Temperature range	Operating -40 ÷ +80 °C; Storage -40 ÷ +80 °C; Fluid: -40 ÷ +85 °C		
Thermal drift	Zero ±0,02 % FS / °C (typ); span ±0,01 % FS / °C (typ)		
Accuracy display	≤ ±1,0 % of FS ±1 digit		
Non-Linearity	≤ ±0,5 % of span BFSL as per IEC 61298-2		
Fluid compatibility	Hydraulic oil as per DIN51524...535; for water-glycol, phosphate ester and skydrol®, please contact Atos technical department		
Power supply	15 ÷ 35 Vdc; I _{max} 600 mA		
N° of outputs	2		
Output type	PNP transistor output (ON state ≡ power supply - 1 V)		
Switching current	250 mA max per output (resistive load)		
Wiring protections	Against reverse polarity on power supply and short-circuit on output signal		
Display	4 digit, 14 segment led, red, height 9 mm		
Materials	Wetted parts: stainless steel 316L (13-8 PH for sensor); seals: FPM/FKM		
Mass	174 g		
Electromagnetic compatibility (EMC)	According to Directive 2014/30/UE EN 61326 emission (group 1, class B) and immunity (industrial application)		
Vibration resistance	10 g according to IEC 60068-2-6, under resonance		
Shock resistance	50 g according to IEC 60068-2-27		
Protection class	IP65 / IP67 with mating connector		
Hydraulic connection	1/4" GAS - DIN 3852 form E (pressure port orifice Ø 0,6 mm)		
Electrical connection	Type: plastic 5 pins M12 at 90° (DIN 43650-C) with cable gland type PG7 for cable max Ø 6 mm Protection: IP67 according to EN 60529; Insulation: according to VDE 0110-C		

Notes: FS = Full Scale; BFSL = Best Fit Straight Line; (1) negative pressure lower than -1 bar can damage the device

3 FEATURES

- Two independent PNP transistor switching outputs. I_{max} up to 250 mA per output
- 4 digit display, adjustable on one axes without tools for best visual position or visualized digits can be turned electronically of 180°
- Pressure reading selectable in: bar, Mpa, kPa, psi, kg/cm²
- Selection of different display modes: unit switching, offset adjustment, actual pressure value, minimum or maximum pressure value, function switch points, function reset points, display updates/second.
- Hydraulic connection G1/4"
- Electric connector M12x1 supplied with the pressure switch

4 OUTPUTS SWITCHING FUNCTION

The independent outputs can be settable using two different functions: Hysteresis and Windows.

Hysteresis function - see 4.1

If the system pressure fluctuates around the set point, the hysteresis keeps the switching status of the outputs stable. With increasing system pressure, the output switches when reaching the switch point (SP).

- HNO - contact normally open: active
- HNC - contact normally closed: inactive

With system pressure falling again, the output will not switch back before the reset point (RP) is reached.

- HNO - contact normally open: inactive
- HNC - contact normally closed: active

Window function - see 4.2

The window function allows for the control of a defined range.

When the system pressure is between window High (FH) and window Low (FL), the output switches on.

- FNO - contact normally open: active
- FNC - contact normally closed: inactive

When the system pressure is outside window High (FH) and window Low (FL), the output does not switch on.

- FNO - contact normally open: inactive
- FNC - contact normally closed: active

Delay times (0 ... 50 s) - see 4.3

This makes it possible to filter out unwanted pressure peaks of a short duration or a high frequency (damping).

The pressure must be present for at least a certain pre-set time for the output to switch on. The output does not immediately change its status when it reaches the switching event (SP), but rather only after the pre-set delay time (DS).

If the switching event is no longer present after the delay time, the switch output does not change.

The output only switches back when the system pressure has fallen down to the reset point (RP) and stays at or below the reset point (RP) for at least the pre-set delay time (DR).

If the switching event is no longer present after the delay time, the switch output does not change.

Delay times is available for Hysteresis and Window functions.

4.1 Hysteresis Function

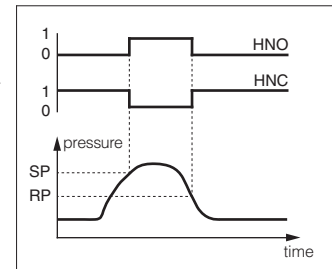

4.2 Window Function

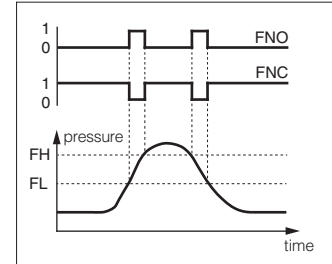

4.3 Delay times (0 ... 50 s)

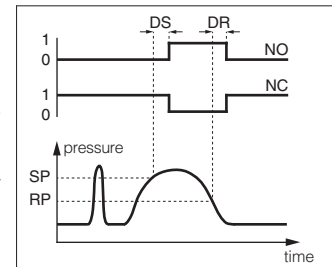

5 INSTALLATION AND USE

E-DAP-2 can be installed in any position.

Rotate the 4 digit display in order to provide the best visual orientation.

Connect M12 electric connector according the wiring diagram in section 6.

Consult the operating manual, supplied with the electronic pressure switch, for the parameters setting.

6 ELECTRONIC CONNECTIONS

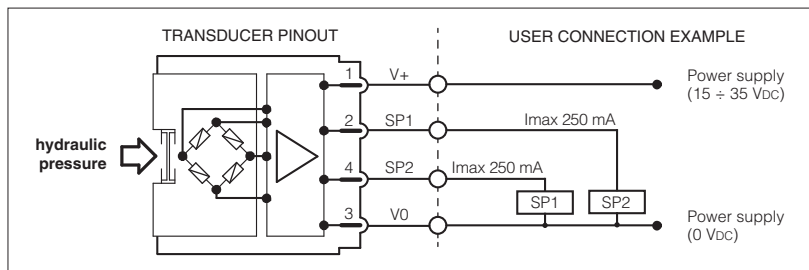

7 OVERALL DIMENSIONS [mm]

